

BRITISH 25PDR. FIELD GUN

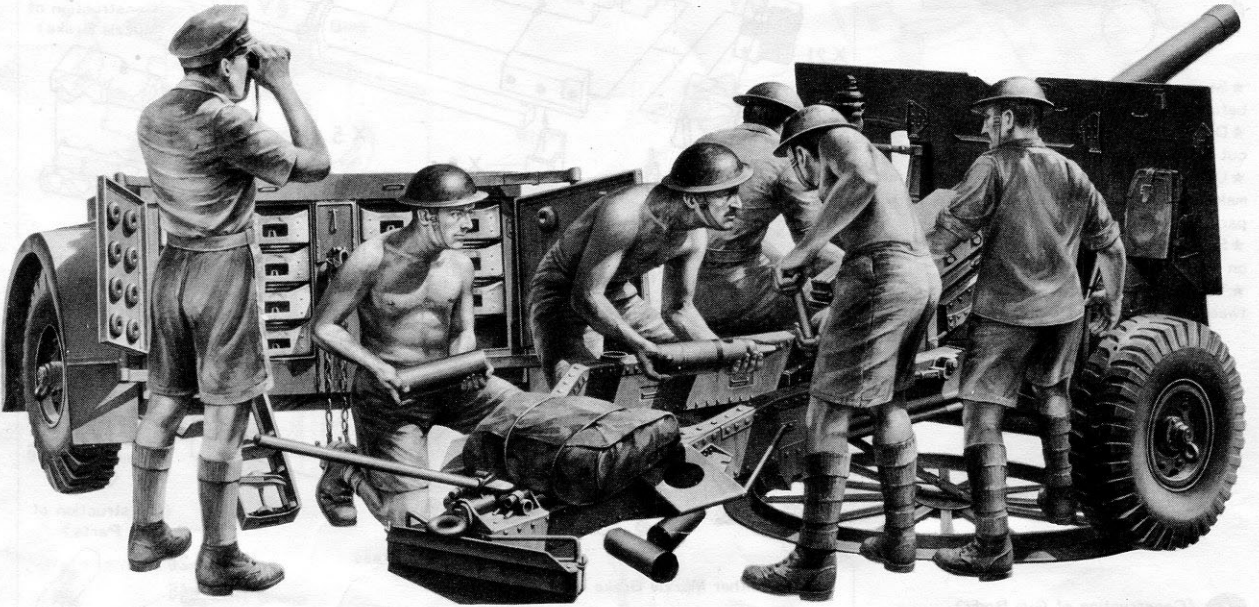

1/35 MILITARY MINIATURE SERIES



In the British Army the Royal Regiment of Artillery has a long and distinguished history. Its motto, which is in Latin, is "UBIQUE QUO FAS ET GLORIA DUCUNT" and means "Everywhere they lead with right and glory". At all ceremonial parades the Royal Artillery takes the position of honour, "the right of the line". Although many types of weapons have been used by the Royal Artillery, ranging from small 2 pdr. anti tank guns right up to 5.5" Howitzers and, in the Garrison Artillery, huge naval type guns, the main weapon which equipped all Field Artillery Regiments attached to Infantry Divisions during World War II was the ubiquitous 25 pdr. This gun was a direct descendant of the famous 18 pdr. which, as a breach loader had been used from about the turn of the century. But the origins of the 18 pdr. go back to smooth bore muzzle loaders of the early 19th century. The British Army still has some 18 pdrs, horse drawn, and these are the equipment of the famous "K" Troop of the Royal Horse Artillery. This famous Troop can be seen at Ceremonial Parades such as the Queen's Birthday, when they still fire the salute. The 25 pdr., directly developed from the 18 pdr., appeared at the beginning of World War II. This 25 pdr. Gun/Howitzer was designed in 1935 and developed to replace the then standard 18 pdr. Field Gun. The final stages of development were hastened by the outbreak of war in 1939. Early deliveries were of a cross-bred equipment - the 18/25 pdr or 25 pdr. Mark 1, which consisted of a relined 18 pdr. piece on the old carriage. The final carriage design - a sturdy, rivetted box trail with a turntable platform under the wheels - was adopted after trials with a heavy 2 legged split trail. This design proved highly successful, giving easy 360 degree traverse despite limited lateral movement of the piece itself. The latest British gun, the 105mm Light Gun, which comes into service in 1975, has the same carriage arrangement. In both cases the platform travels under the trail and is lowered for firing. The platform digs-in to give stability and the trail spade is rarely needed. A spade box normally covers it, and allows the trail to be lifted to traverse the gun. The whole Gun was extremely rugged in its design, and in 34 years has had only one major modification, the adoption of a double baffle muzzle-brake in 1943. Not only was the design sturdy, but the whole equipment was easy to operate and maintain. The

calibrating sights, with a range drum, were simple to use, and the associated command post drills were equally simple. The ammunition options available at the peak of development were very wide: HE, smoke, coloured smoke, solid shot, cannister, HEAT and illuminating. The smoke round was of the base ejection type. This takes longer to produce a screen than the then currently fashionable White Phosphorous Smoke. However, it was more economic in some circumstances, and often provided a more effective screen once it was under way. The shell type could be put to other uses, such as pamphlet propagation. Several fuses were developed; percussion, mechanical time, variable time (radar) and powder burning. The ammunition was separate. The shell was rammed by hand before the brass cartridge was loaded. Loading was therefore a two-man job. A high rate of fire could be achieved by a well-trained detachment - say 8 rounds per minute for several minutes, although the official rapid rate was 5 rounds per minute. Three basic charges were provided, each represented by a coloured bag in the cartridge case. Incremental charge bags were developed, but never widely adopted, to give an even better "charge overlap" in range. "Charge Super" was a special cartridge. During the desert campaigns the gun was used extensively in an anti-tank role. A super charge cartridge (with increment) was produced to increase the muzzle velocity of the solid shot anti-tank round to 2,000 feet per second. Remarkably, the only modification needed to cope with the additional stresses was the muzzle brake already mentioned. This device aided stability as much as it reduced recoil forces. The 25 pdr. Gun Detachment consisted of six men, who were as follows: Gun Commander, Gun Layer, Loader, 2 Ammunition Numbers, and Driver. Several Self Propelled versions were produced. Only the Bishop (Valentine chassis) and Sexton (Canadian Ram chassis) saw service. The Gun's main weakness was its weight - 1,750 kg. For many years a two-wheel limber/trailer between the gun and tractor enabled a light towing vehicle to be used. This was the purpose built Quad. The device served the double purpose of carrying first line ammunition and reducing the weight on the tractor's towing eye and back axle. The alternative (adopted towards the end of the gun's useful life) was a 3 ton vehicle. In both cases cross

country mobility was limited. For weight reasons an airborne version was never adopted. A special, narrow platform was developed for use in the jungles of South East Asia. By the time the gun was pensioned off in 1967, its range (13,500 yards) and the lethality of its 25 pound shell had been overtaken by technological progress. Its descendant, the Light Gun, has 50% more range and shell weight for the same weight of gun. More than 12,000 25 pdrs. were produced and used throughout the world by Commonwealth, Middle Eastern and other allied armies. It is still active in some parts today, but in the British Army it is now used only for training purposes. Perhaps its last major campaign was the Indo-Pakistan War of 1971. Despite its long history of service, the 25 pdr. is best remembered for its part in the campaigns in the Western Desert, and then for its anti-tank performance. In fact it was the basic close support artillery weapon of half the Western World for 30 years. In World War II an Infantry Division had three Royal Artillery Regiments, each one attached to its Brigade. The Marking of their vehicles was 42, 43 and 44 on a red over blue background, the Senior Regiment having the Number 42 and the Junior Number 44. Each Regiment had 24 guns divided into three Batteries of 8 guns each, and each Battery was divided into two troops of 4 guns each. The 25 pdr. was renowned for its extreme accuracy when used in its conventional role. This was due to a very cleverly designed gun sight which was known as a Dial Sight. This allowed for wind, temperature of air and other factors. Rarely were more than three shots required to hit a target. The first two bracketed, and on instructions from the O.P. (Observer Post) the order would be given to the guns to either "Up 100" or "Down 100" and the third shot was the one that mattered. Although it was usual for the guns to be dug into gun pits and camouflaged, they were able to go into emergency action from the march within about 45 seconds. So rapid was their firing rate that German prisoners of war taken in Normandy asked to see the "Belt Fed" 25 pdr. gun, as they could not believe that the gun was hand loaded, such was the rapidity of fire.



- ★ Study the instructions and photographs before commencing assembly.
- ★ Do not break parts away from sprue, but cut off carefully with a pair of pliers.
- ★ Use glue sparingly. Use only enough to make a good bond. Apply cement to both parts to be joined.
- ★ Small parts should be painted while still on the sprue.
- ★ You will need a sharp knife, a pair of tweezers, a file, and a pair of pliers.

1 (Construction of Gun Body)

Assemble Gun Body Halves X5 and X6, Breech Mechanism Halves X21 and X22. And then cement both of them together. Breech Block X28 is movable. Insert this into Breech Mechanism without glue.

2 (Fixing of Cradle)

Cement Cradle Halves X32 and X33 together, while making Gun Body slide smoothly between them. Muzzle Brake was attached to the later version of 25Pdr. Gun. And part X55 is prepared for the earlier one. Select either one and fix.

3 (Construction of Trail)

Cement Trail Halves X38 and X39 together and fix Top Plate X19. You will get perfect fit if you file their areas to be joined together.

4 (Completion of Trail)

Cement Handles X47 and X48 to Spade X37 and fix to Trail Body.

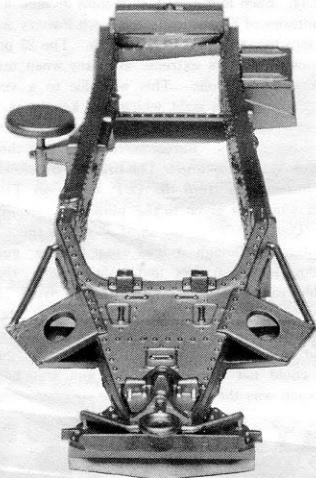

1 Construction of Gun Body

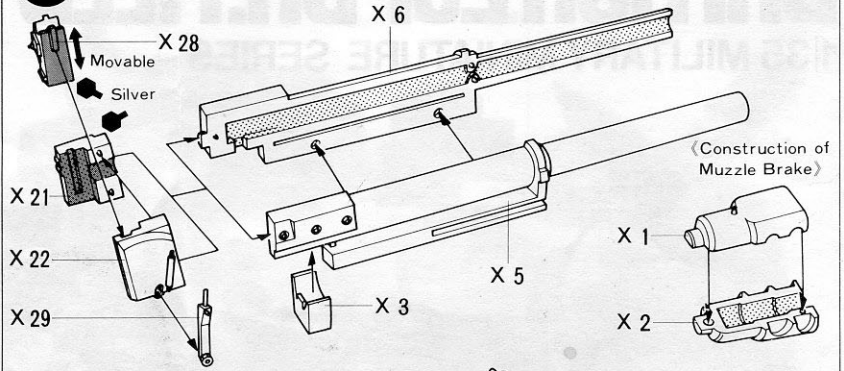

2 Fixing of Cradle

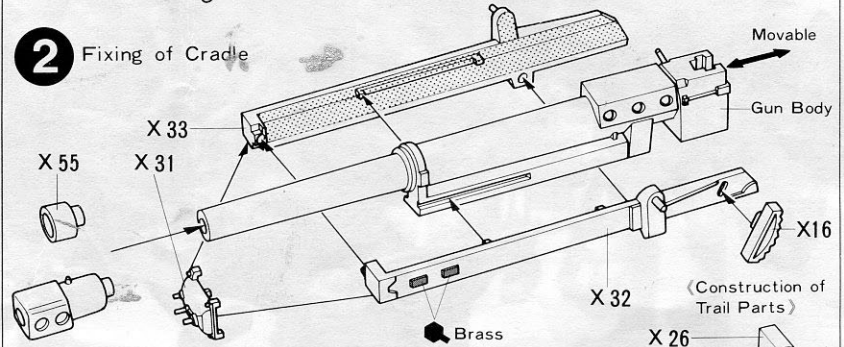

★ Select either Muzzle Brake or X55 and cement.

3 Construction of Trail

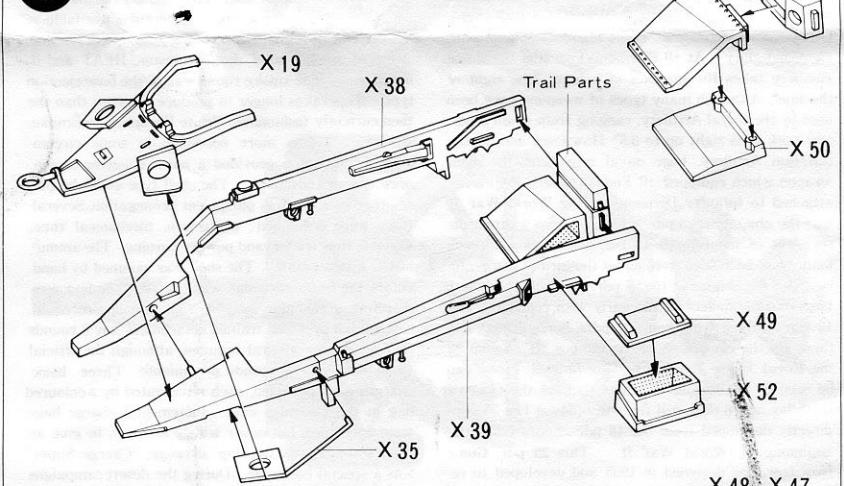

4 Completion of Trail

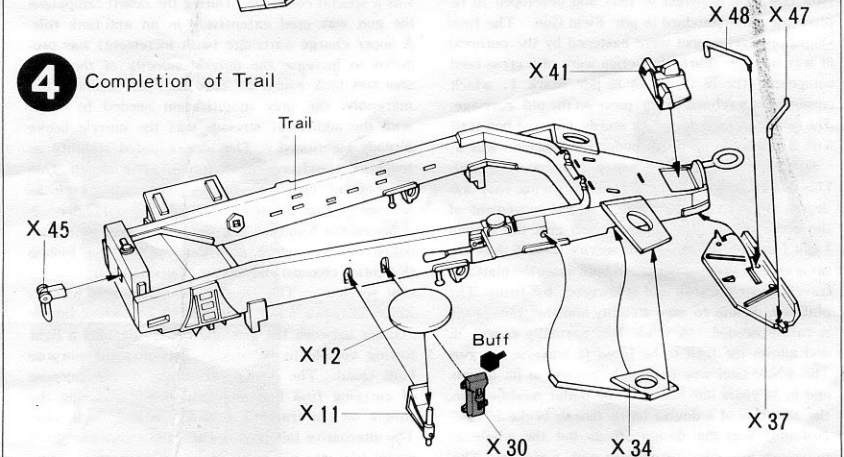

5 (Fixing of Gun Body)
 When you construct Left Saddle, make sure of numbers and positions of various parts.
 Cement Shield Supporting Stays X13 and X14 after fixing Gun Body.

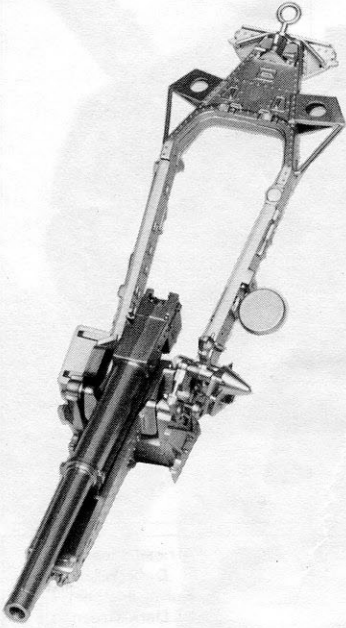

5 Fixing of Gun Body

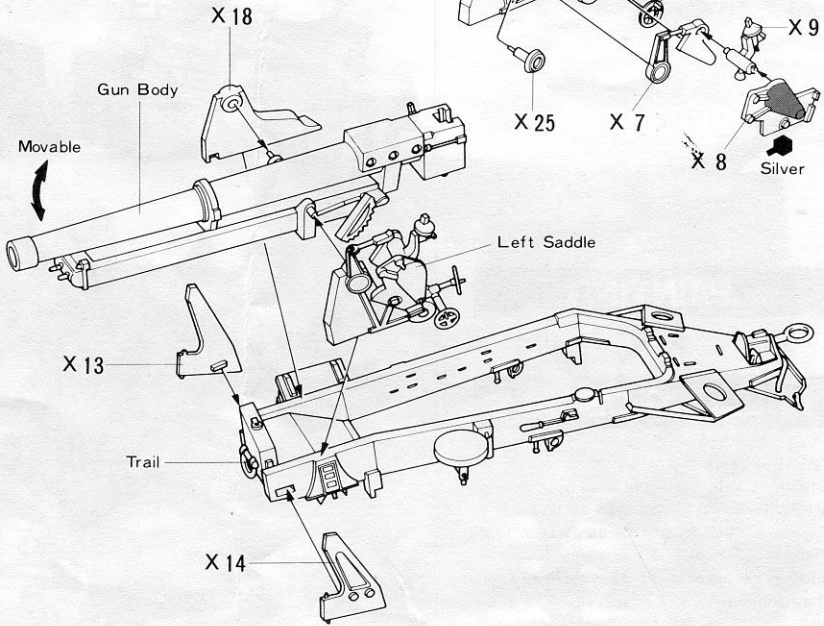

6 (Construction of Shield)
 Fix various parts to respective sides of Shield X15.

7 (Fixing of Shield)
 Fix Shield to Shield Supporting Stays X13 and X14.
 Rod X56 was used to change the direction of the gun when firing. If you wish to make the firing gun fix this.

6 Construction of Shield

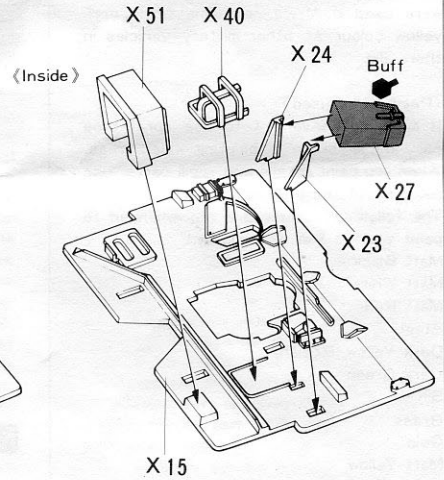
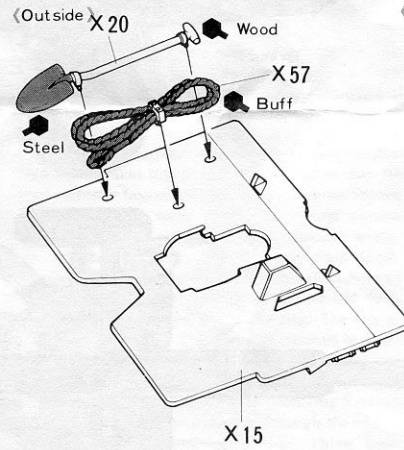

7 Fixing of Shield

★ Cement Shield to X13 & X14.
 ★ X56 is fixed only when firing.

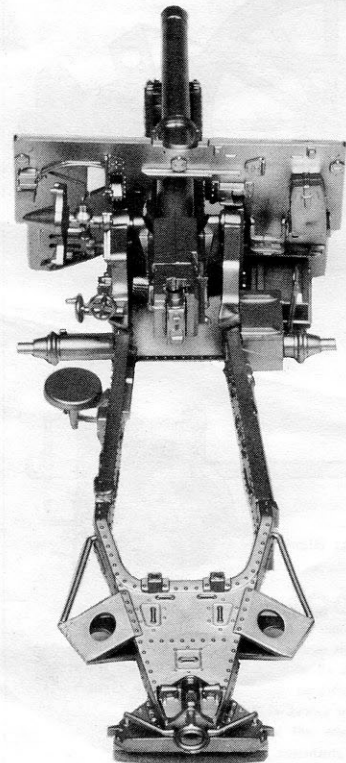
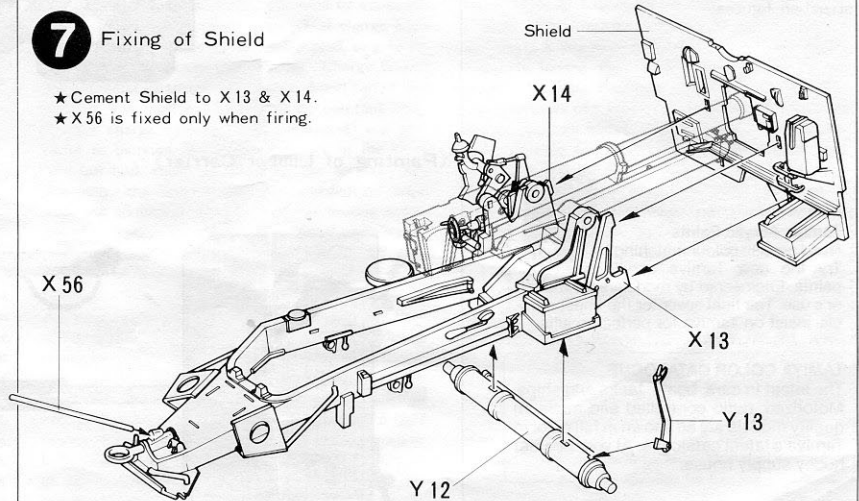

〈Fixing of Accessory Parts and Positioning of Figures〉

Accessory parts and figures should be fixed in position as shown in the right photo.

PAINTING & APPLYING DECALS

〈Painting of 25 Pdr. Gun〉

British 25 Pdr. Guns had been used through a long period, from the German Invasion to France in 1940 to the Korean War in 1950. Though various painting schemes were adopted according to the terrain where they showed activity, generally dark green was applied as a base. And those which were used in Africa carried a single dark yellow colour as other military vehicles in there did.

〈Paint to be used〉

It might be convenient to use spray-type paint and air-brush in painting wider areas. When you paint details and small parts, use paint brush and brush-type paint.

The following colours are recommended to paint your 25 Pdr. Gun model.

- Matt Black
- Matt White
- Matt Red
- Steel
- Dark Yellow (British)
- Dark Green
- Silver
- Brass
- Gold
- Matt Yellow
- Silver

★Detail paintings are indicated in the construction figures.

〈Fixing of Accessory Parts and Positioning of Figures〉



〈Painting of 25 Pdr. Gun〉

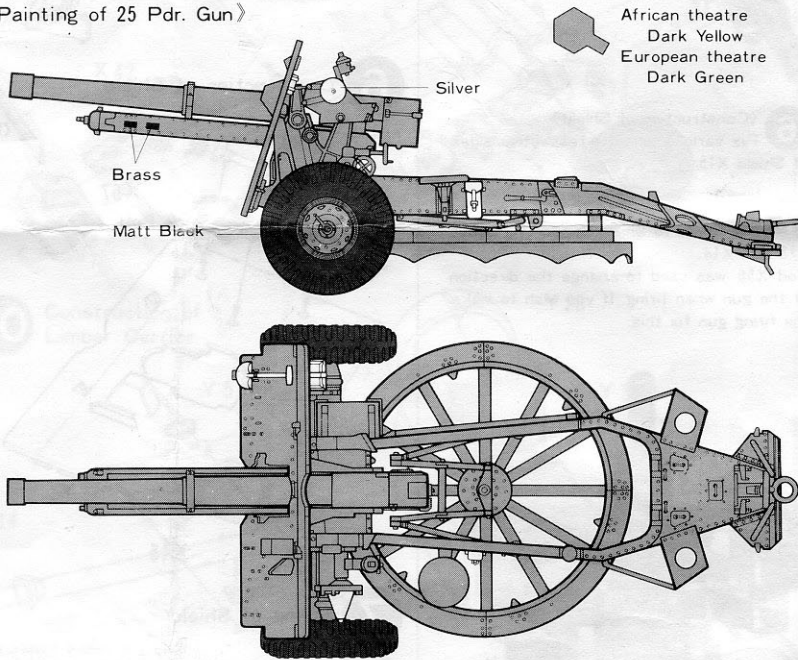

〈Painting of Limber Carrier〉

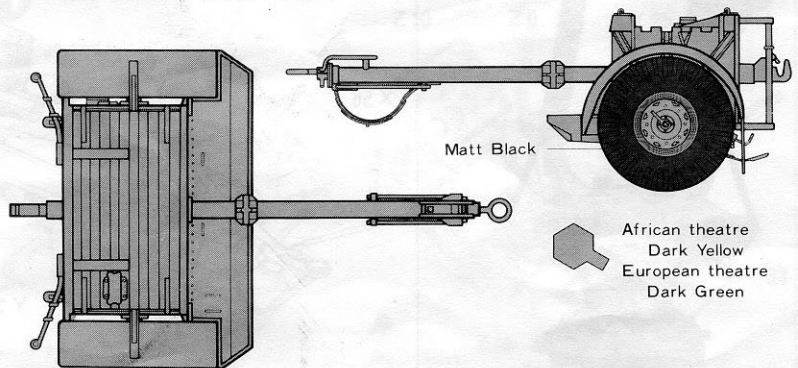

Tamiya Acrylic Paints
Need precise colour matching?
Try the new Tamiya acrylic paints. Engineered by modelers for modeler's use. The final cover for the finest models. Insist on Tamiya for perfect results.

TAMIYA COLOR CATALOGUE
The latest in cars, boats, tanks and ships. Motorized, radio controlled and museum quality models are all shown in full color in Tamiya's latest catalogue. At your nearest hobby supply house.



8 (Construction of Wheels and Firing Platform)

Make four sets of Wheels, two for Gun and two for Limber Carrier.

Firing Platform can be constructed into either transporting or firing position. Select one you prefer and assemble. This part was fixed to make the gun traverse quickly.

9 (Fixing of Firing Platform)

Photos below show transporting and firing positions.

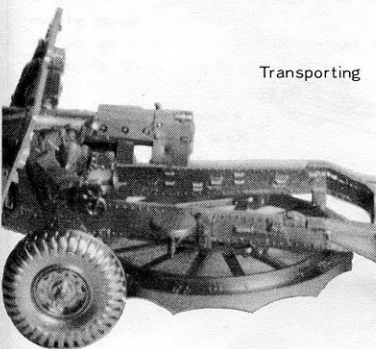

Transporting

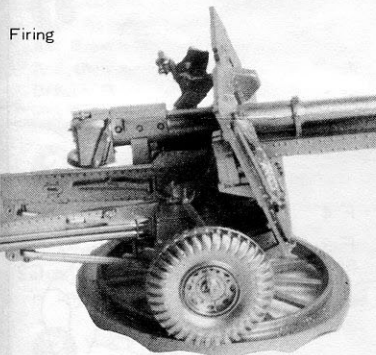

Firing

10 (Construction of Limber Carrier)

Cement Y20 before fixing Y27 to Y30.

(Reference Plan for Fixing of Fenders)

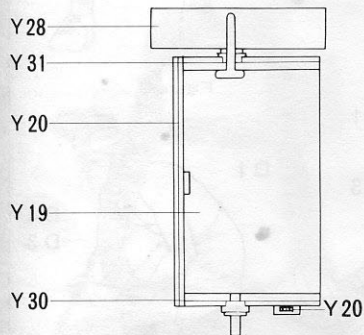

11 (Construction of Rear Panel)

Two kinds of Rear Panels are included in this kit, firing (open) and transporting (closed). Select either one and cement.

8 Construction of Wheels and Firing Platform

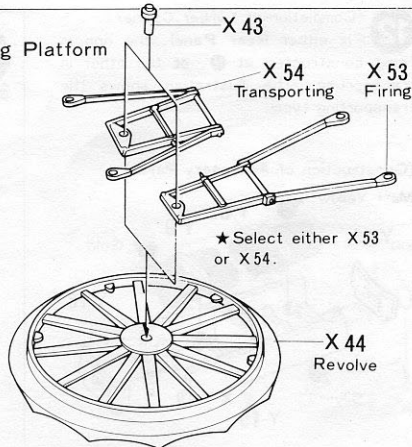
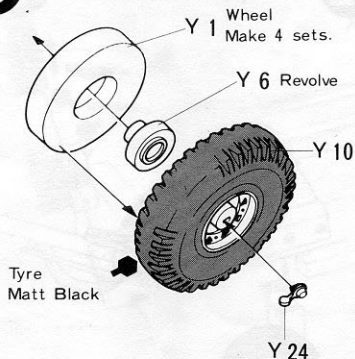

9 Fixing of Firing Platform

★ See the left photo and fix Firing Platform.

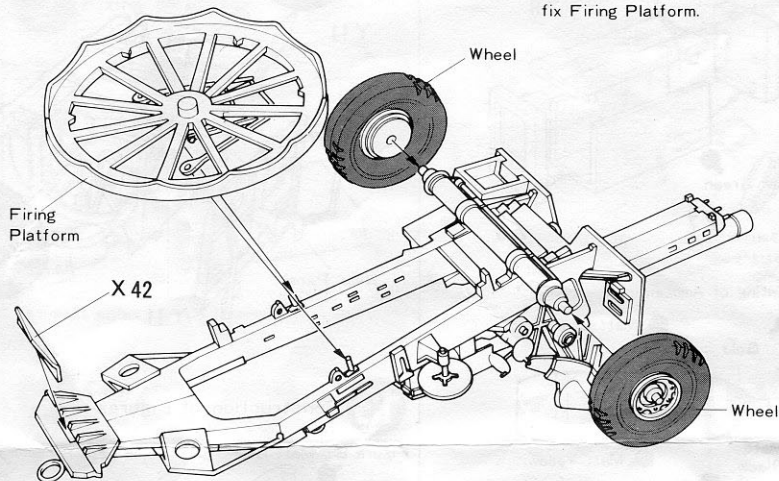

10 Construction of Limber Carrier

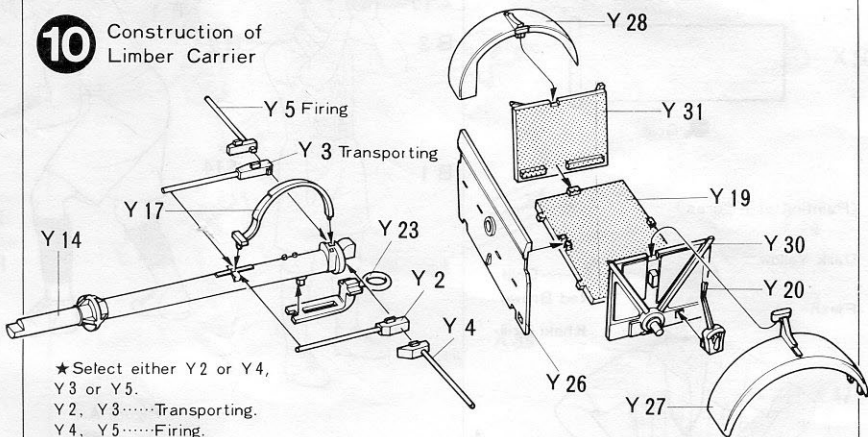

★ Select either Y2 or Y4, Y3 or Y5.
Y2, Y3.....Transporting.
Y4, Y5.....Firing.

11 Construction of Rear Panel

(Transporting)

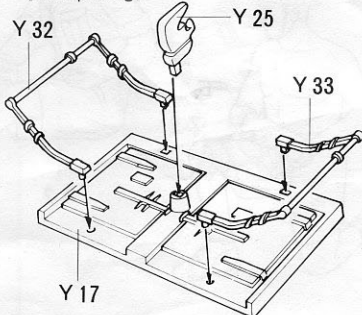

(Firing)

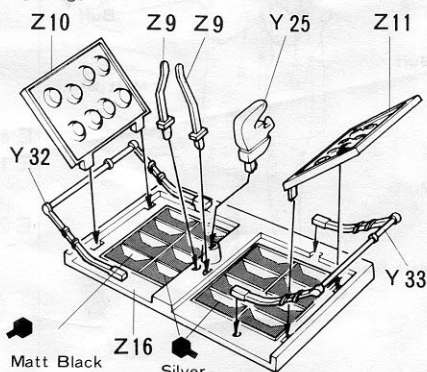

12 (Completion of Limber Carrier)
 Fix either Rear Panel, the one in firing constructed at ①, or the other in transporting. The illustration shows the transporting type.

(Construction of Accessory Parts)

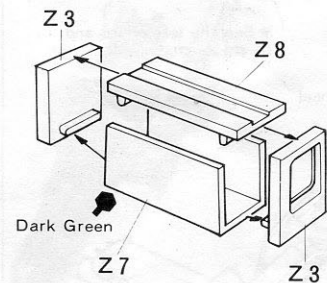
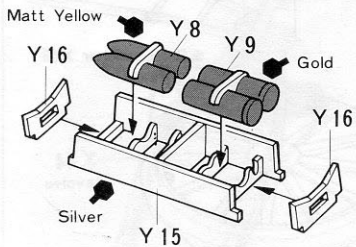

(Painting of Ammunition)

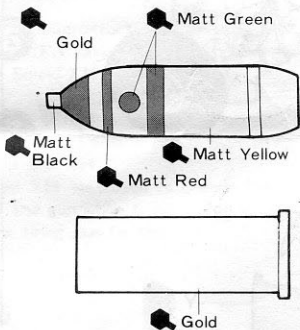

(Painting of Figures)

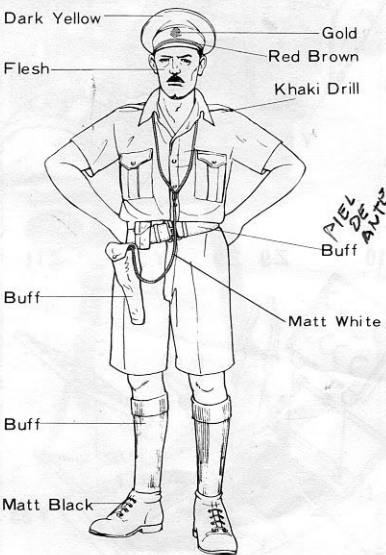

12 Completion of Limber Carrier

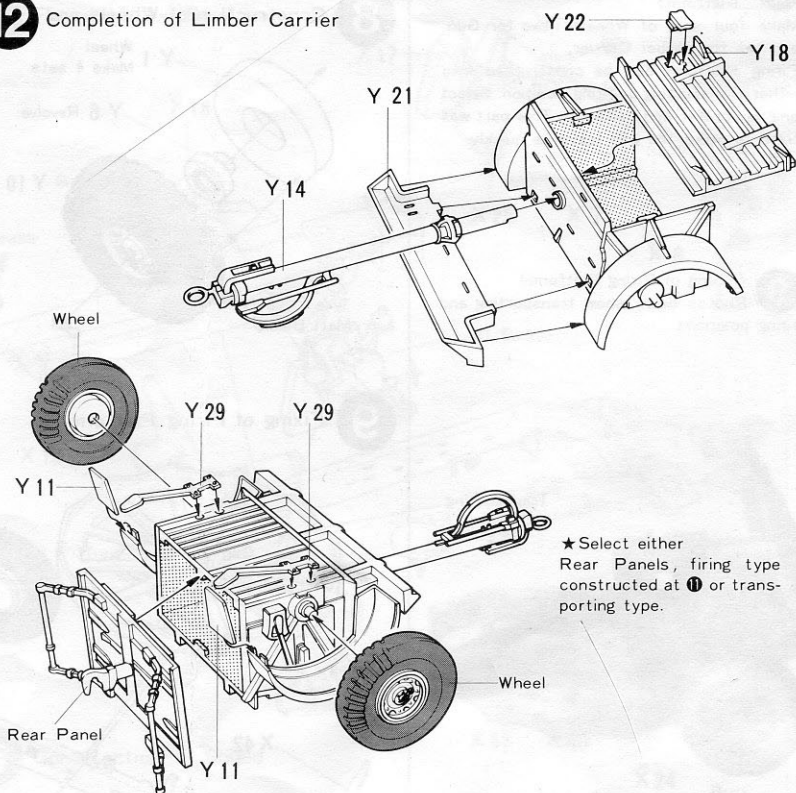

13 Construction of Figures

Figure B Matt Black



Figure F

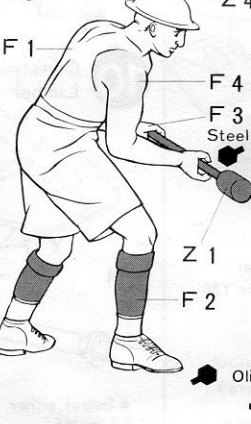

Figure C



Figure A



Figure D

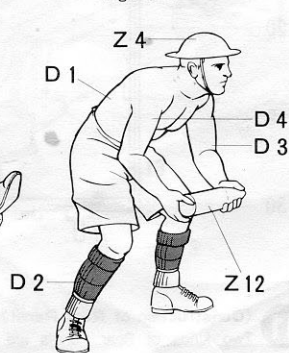

Figure E

